

**SONY**<sup>®</sup>

Data Projector

**VPL-FX51**





simulated picture



simulated picture

# The new Sony VPL-FX51 Data Projector

—where style meets  
innovation.



**Super-high 5200-ANSI-lumens brightness  
and excellent contrast  
for your presentations and video images**

In auditoriums or business conferences, for seminars or school education, the VPL-FX51 lets you captivate audiences with a new world of breathtaking image quality. Delivering a high-brightness output of 5200 ANSI lumens\* and attractive, high contrast ratio that is twice as high as conventional Sony products, it also enables you to give high-impact multimedia presentations.

Seen from any angle, this beautifully designed projector brings an elegant and stylish addition to any display environment. Its outstanding functionality – including Sony-originated software and a networking capability – means you can show your presentations and image files from anywhere with the same impressive ease and results.

\*ANSI lumens is a measuring method of the American National Standards Institute IT 7.228. Since there is no uniform method of measuring brightness, specifications will vary among manufacturers.

# Features

## Outstanding Brightness of 5200 ANSI Lumens

The Sony VPL-FX51 Data Projector achieves an outstanding brightness of 5200 ANSI lumens and a contrast ratio that is twice as high as conventional Sony products for dynamic, large-screen displays. The high aperture ratio, 1.3-inch LCD panels, together with a Micro Lens Array, provide significant light-



transmission efficiency. By combining this advanced Sony LCD technology with a new 300-W UHP lamp, you can bring high-impact images to life with stunning color fidelity.

## Elegant Design

You'll be attracted to the VPL-FX51 not only because of its beautiful projected images, but also its simple yet sophisticated design – making a statement even before it's turned on. The exhaust and connector panel are located on the front of the unit so that the

projector will blend in smoothly with its installation environment. It has also been designed with symmetry in mind, with the centralized lens offering simple, balanced installation design.

## High Quality and Performance

### Dynamic Detail Enhancer (DDE) For High-Quality Video Images

The unique Sony video-enhancing technology generates high-quality images of outstanding clarity. For video sources, I/P (Interlace/Progressive) conversion is applied to interlace signals to project clear and sharp progressive images. When displaying film-originated sources, signals converted by 2-3 pull down\* are detected, and each frame of the original film is

accurately reproduced.

The VPL-FX51 projects images with a high degree of accuracy by adopting new driver circuitry that enables it to accept digital signals directly.

\* 2-3 pull down is only available for 60-Hz signals (NTSC).

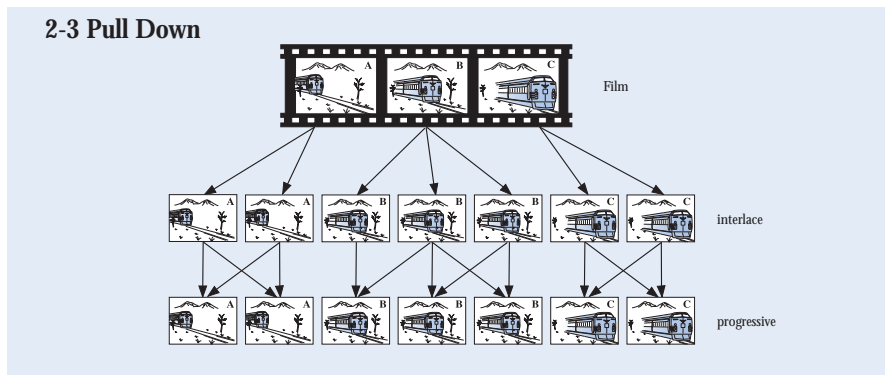
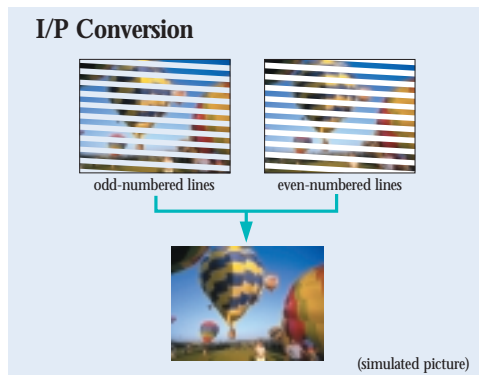

### RGB Enhancer

The RGB Enhancer can be adjusted from the On-Screen Display, for enriched and crisp RGB image reproduction.



### 3D Gamma Correction

10-bit 3D Gamma Correction circuitry performs highly accurate gamma correction to give uniform image color and brightness that extend right to the corners of the screen.

### 3D Digital Comb Filter

Thanks to the Sony-originated 3D Digital Comb Filter that separates Y signals from C signals with great accuracy, it is easy to emphasize fine images and shape boundaries.

# Features

## Installation Flexibility

### Power Zoom/Focus/Picture Shift

The Zoom, Focus and Picture Shift functions of the supplied power-operated lens can be controlled both from the projector control panel and the supplied remote-control unit\*. Images can be easily adjusted to the desired settings.

\* Standard lenses include motorized Zoom and Focus. Picture Shift function only supported by optional lenses, which do not include motorized Zoom or Focus.

### Back to Front Tilt

The VPL-FX51 can be tilted 90 degrees upwards or downwards. This flexibility greatly expands your application possibilities.

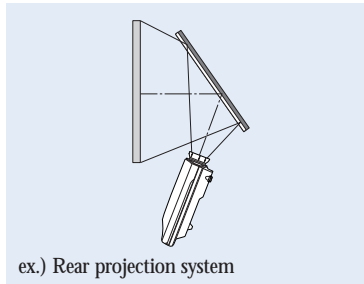

### Stacking Capability

When applications require double the light output, the VPL-FX51 can be twin-stacked\*. Pictures from the two projectors are then matched using the Picture Shift function on each unit.

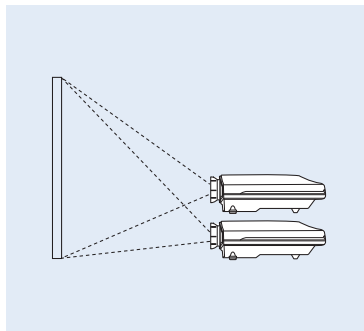

\* The optional VPLL-FM21 projection lens cannot be used when the PL-FX51 is stacked.

### Various Inputs

The VPL-FX51 accepts a wide variety of input signals, including video, S-video, DTV and HDTV, as well as computer signals up to UXGA (fV: 60 Hz), expanding its system-connection possibilities. It also has a DVI input, so you can take advantage of the new standard for the direct transfer of digital and analog signals from a PC.

### Digital Keystone Adjustment

Keystone distortion of up to  $\pm 20$  degrees can be digitally corrected via the On-Screen Display. This enables detailed images to be projected with their correct geometry, even when installation space is limited.



### Direct Power On

Turning on this function enables you to skip standby mode and activate the VPL-FX51 immediately. This function is ideal for large-scale facilities such as museums, auditoriums and conference halls, with images ready for projection as soon as you turn on the circuit-breaker switch on the switchboard.

### Variety of Lenses

The VPL-FX51 is supplied with a power lens as standard, with three alternative lens types available as options. This choice of lenses enables the VPL-FX51 to be installed in a wide range of applications – from long-distance projection in large auditoriums to short-distance rear projection applications.

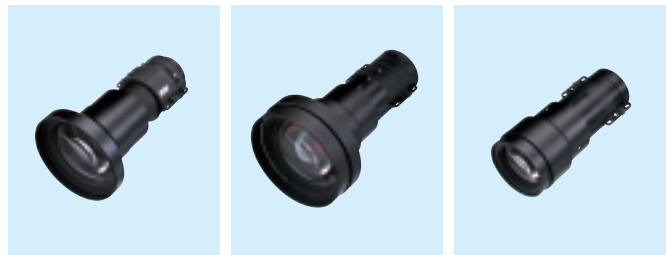

Projection Lens  
VPLL-FM21

Projection Lens  
VPLL-ZM31

Projection Lens  
VPLL-ZM101



# Network Capability

## Network Connections

The VPL-FX51 includes a 10Base-T/100Base-TX Ethernet interface and a PC Card slot for wired/wireless connection to the network. This network connection gives the VPL-FX51 great flexibility and efficiency.

\* Specified/Recommended Wireless LAN PC Card and PC Memory Card may vary by area. For details, please contact your nearest Sony office.

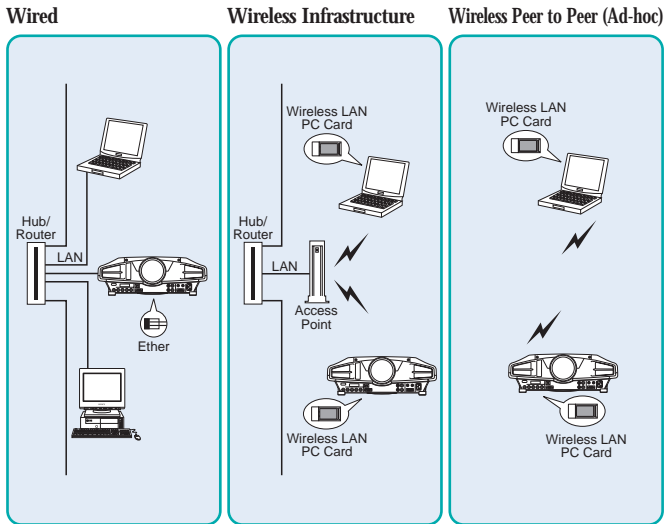

## Easy Maintenance Access

The network connection allows you to monitor and control multiple projectors in one system. As long as the PC used is within the network environment, maintenance can be carried out centrally from virtually any location.

### • Information access via a web browser

Using a web browser, you can check the projector's current status and version information from any PC on the same network.

### • E-mail reports

The automatic e-mail service sends regular status reports (including lamp life, maintenance scheduling, etc) and error reports to a designated recipient.

### • SNMP support

The VPL-FX51 complies with the Simple Network Management Protocol (SNMP).

### • Remote projector control

In addition to remote control using the RS-232C interface, the VPL-FX51 can also be accommodated in various network-based control systems via TCP/IP.



## Presentations from a Networked PC

You can use any PC on the same network to communicate with the VPL-FX51, via a web browser. This enables you to give presentations through the network without connecting the projector and PC using an RGB cable. You can also prepare presentation files in the projector memory prior to a meeting or event simply by sending files to the projector across the network.

\* System requirements:

OS: Microsoft® Windows® 98, Windows 98 SE, Windows ME or Windows 2000, Windows XP Professional

Web browser: Microsoft Internet Explorer 5.0 or later.

## PC-less Presentations

Alternatively, it is not even necessary to use a PC to deliver presentations. You can access files and project them effortlessly using the supplied remote control unit alone.

### • File access via the network

When the projector is connected to the network, shared files can be retrieved and opened for projection from the Network Projector startup window.

### • Remote Desktop function

The VPL-FX51 also supports a Remote Desktop function, which allows it to access any data or application stored on a networked PC running a Microsoft Windows XP Professional system.

### • PC Card presentations

Presentation files can also be projected directly by inserting the PC Memory Card into the PC Card slot.

## Application Software for Presentation Control

The VPL-FX51 includes a selection of original Sony application software. The Presentation Viewer\* enables you to prepare and run PowerPoint (PPT, PPS), Excel (XLS) and Word (DOC) presentation files, while the Image Viewer allows for JPEG/GIF/BMP/PNG presentations. Presentation files in the projector memory can also be added or deleted using the File Manager.

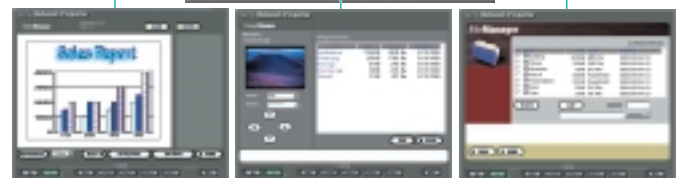
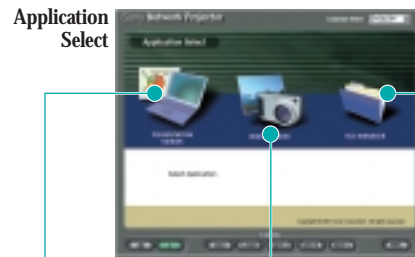

Presentation Viewer

Image Viewer

File Manager

\* Some functions with which original files are equipped may not work because the Presentation Viewer is only a basic viewer.

# Features

## Other

### Multi-Function Remote-Control Unit

The supplied remote-control unit is useful for both projector setup and delivering presentations. Functions such as lens control, mouse control, Digital Zoom and Freeze can be operated from this wireless control unit, while the built-in laser pointer is a useful tool for more effective presentation. In addition, function keys on the remote-control unit provide easy startup of network functions, and network applications can be launched at the push of a button.

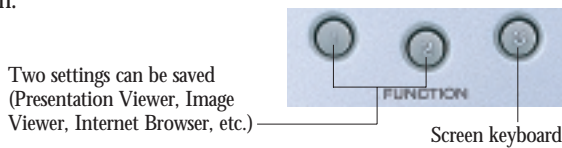

### Digital Zoom

With the 4-times Digital Zoom, you can zoom in on one section of the presentation for a closer look, to convey your message more clearly.

### Freeze

For smart presentations, the Freeze function displays a freeze-frame while you are preparing or switching to the next image.

### APA (Auto Pixel Alignment)

Dot phase and image size or shift can be automatically adjusted to their optimal settings simply by pressing the APA button.

### Easy Maintenance

The projector's required air filter cleaning cycle coincides with the recommended lamp replacement cycle, meaning you can perform maintenance on both at the same time.

### Low Fan Noise

The VPL-FX51 realizes low fan noise for smooth, undisturbed presentations.

### On-Screen Display (OSD)

The On-Screen Display – used to control the projector – is available in nine languages: English, French, Spanish, German, Italian, Japanese, Chinese, Portuguese and Korean.



# Optional Accessories



Projector Lamp (for replacement)  
**LMP-F300**



Suspension Support  
**PSS-620**



Video Signal Cables  
**SMF-400**  
HD D-sub 15-pin to 5 BNC

	Fixed Short Focus Lens	Zoom Short Focus Lens		Zoom Long Focus Lens	
	VPLL-FM21	VPLL-ZM31		VPLL-ZM101	
F	2.0	1.9-2.0		2.0-2.6	
Throw ratio*1	0.9:1	1.55-1.7:1		3.3-5.0:1	
Zoom	—	x 1.1		x 1.5	
Throwing Distance		Wide	Tele	Wide	Tele
Screen size*2					
40-inch	690 mm	1190 mm	1250 mm	2600 mm	3890 mm
60-inch	1080 mm	1840 mm	1940 mm	4000 mm	5940 mm
80-inch	1460 mm	2490 mm	2620 mm	5410 mm	7980 mm
100-inch	1850 mm	3150 mm	3300 mm	6810 mm	10030 mm
120-inch	2240 mm	3800 mm	3980 mm	8220 mm	12080 mm
150-inch	2820 mm	4780 mm	5000 mm	10330 mm	15150 mm
200-inch	3780 mm	6410 mm	6710 mm	13840 mm	20270 mm
250-inch	4750 mm	8050 mm	8410 mm	17350 mm	25380 mm
300-inch	5720 mm	9680 mm	10120 mm	20870 mm	30500 mm

\*1 Distance between the center of the projector lens and the screen, divided by the screen width.

\*2 Viewable area, measured diagonally.

# Installation Data

## Floor Installation

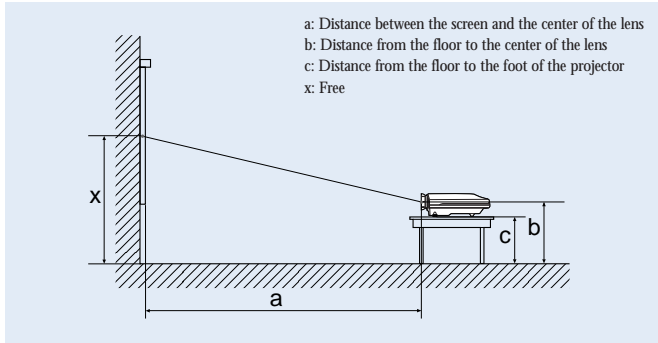

Screen size*	40	60	80	100	120	150	200	250	300	
a	min	mm 1490 (inches 58 3/4)	mm 2280 (inches 89 7/8)	mm 3060 (inches 120 1/2)	mm 3850 (inches 151 5/8)	mm 4630 (inches 182 3/8)	mm 5810 (inches 228 7/8)	mm 7770 (inches 306)	mm 9730 (inches 383 1/8)	mm 11690 (inches 460 3/8)
	max	mm 1820 (inches 71 3/4)	mm 2780 (inches 109 1/2)	mm 3740 (inches 147 3/8)	mm 4700 (inches 185 1/8)	mm 5660 (inches 222 7/8)	mm 7100 (inches 279 5/8)	mm 9500 (inches 374 1/8)	mm 11900 (inches 468 5/8)	mm 14300 (inches 563 1/8)
b	min	mm x-305 (inches x-12 1/8)	mm x-457 (inches x-18)	mm x-610 (inches x-24 1/8)	mm x-762 (inches x-30)	mm x-914 (inches x-36)	mm x-1143 (inches x-45)	mm x-1524 (inches x-60)	mm x-1905 (inches x-75 1/8)	mm x-2286 (inches x-90 1/8)
	max	x								
c	min	mm x-415 (inches x-16 3/8)	mm x-567 (inches x-22 3/8)	mm x-720 (inches x-28 3/8)	mm x-872 (inches x-34 3/8)	mm x-1024 (inches x-40 3/8)	mm x-1253 (inches x-49 3/8)	mm x-1634 (inches x-64 3/8)	mm x-2015 (inches x-79 11/32)	mm x-2396 (inches x-94 3/8)
	max	mm x-100 (inches x-4)								

\* Viewable area, measured diagonally.

## Ceiling Mount Installation

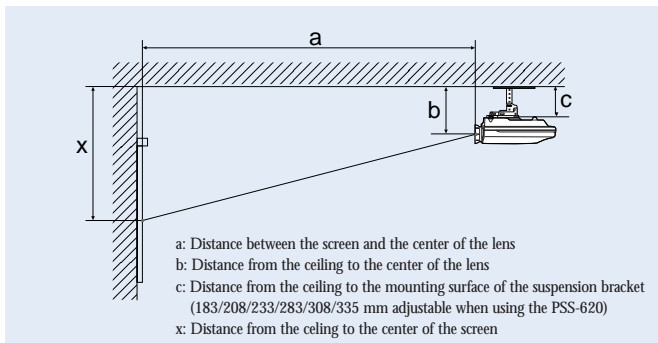

Screen size*	40	60	80	100	120	150	200	250	300	
a	min	mm 1490 (inches 58 3/4)	mm 2280 (inches 89 7/8)	mm 3060 (inches 120 1/2)	mm 3850 (inches 151 5/8)	mm 4630 (inches 182 3/8)	mm 5810 (inches 228 7/8)	mm 7770 (inches 306)	mm 9730 (inches 383 1/8)	mm 11690 (inches 460 3/8)
	max	mm 1820 (inches 71 3/4)	mm 2780 (inches 109 1/2)	mm 3740 (inches 147 3/8)	mm 4700 (inches 185 1/8)	mm 5660 (inches 222 7/8)	mm 7100 (inches 279 5/8)	mm 9500 (inches 374 1/8)	mm 11900 (inches 468 5/8)	mm 14300 (inches 563 1/8)
b	min	mm c+91.4 (inches (c+3 5/8))								
	max	mm c+101.4 (inches (c+4))								
x	min	mm c+100 (inches (c+4))								
	max	mm c+406 (inches (c+16))	mm c+558 (inches (c+22))	mm c+711 (inches (c+28))	mm c+863 (inches (c+34))	mm c+1015 (inches (c+40))	mm c+1244 (inches (c+49))	mm c+1625 (inches (c+64))	mm c+2006 (inches (c+79))	mm c+2387 (inches (c+94))

\* Viewable area, measured diagonally.

# Signal Data

## Preset Signal Chart

No.	Resolution	fH(kHz)	fV(Hz)	H/V		
1	VIDEO 60Hz	15.734	59.940	N/N		
2	VIDEO 50Hz	15.625	50.000	N/N		
3	480/60i	15.734	16.734	SonG/Y or Composite sync		
4	575/50i	15.625	50.000			
5	1035/60i, 1080/60i	33.750	60.000			
6*	640x350	VGA-1	31.469		70.086	P/N
7*		VGA VESA 85	37.861		85.080	P/N
8*	640x400	NEC PC98	24.823	56.416	N/N	
9		VGA VESA-2	31.469	71.086	N/P	
10		VGA VESA 85	37.861	85.080	N/P	
11*	640x480	SVGA VESA 60	31.469	59.940	N/N	
12*		Mac 13	35.000	66.667	N/N	
13*		VGA VESA 72	37.861	72.809	N/N	
14*		VGA VESA 75	37.500	75.000	N/N	
15*		VGA VESA 85	43.269	85.008	N/N	
16*	800x600	SVGA VESA 56	35.156	56.250	P/P	
17*		SVGA VESA 60	37.879	60.317	P/P	
18*		SVGA VESA 72	48.077	72.188	P/P	
19*		SVGA VESA 75	46.875	75.000	P/P	
20*		SVGA VESA 85	53.674	85.061	P/P	
21*	832x624	Mac 16	49.724	74.550	N/N	
22*	1024x768	XGA VESA 43	35.524	43.479	P/P	
23*		XGA VESA 60	48.363	60.004	N/N	
24*		XGA VESA 70	56.476	69.955	N/N	
25*		XGA VESA 75	60.023	75.029	P/P	
26*		XGA VESA 85	68.677	84.997	P/P	
27*	1152x864	SXGA VESA 70	63.995	70.019	P/P	
28*		SXGA VESA 75	67.500	75.000	P/P	
29*		SXGA VESA 85	77.487	85.057	P/P	
30*	1152x900	SUN LO	61.795	65.960	N/N	
31*		SUN HI	71.713	76.047	Composite sync	
32*	1280x960	SXGA VESA 60	60.000	60.000	P/P	
33		SXGA VESA 75	75.000	75.000	P/P	
34*	1280x1024	SXGA VESA 43	46.433	43.436	P/P	
35		SXI-5	53.316	50.062	SonG	
36*		SXGA VESA 60	63.974	60.013	P/P	
37		SXGA VESA75	79.976	75.025	P/P	
38		SXGA VESA85	91.146	85.024	P/P	
39	1600x1200	UXGA VESA60	75.000	60.000	P/P	
43	480/60p (Progressive Component)		31.470	60.000		
44	575/50p (Progressive Component)		31.250	50.000		
45	1080/50i		28.130	50.000		
47	720/60p		45.000	60.000		
48	720/50p		37.500	50.000		

\* If you would like to input a signal that is not listed in the above chart, please contact your local Sony sales office.

\*\* The digital input complies with all signals marked with an asterisk in the table. When the digital signal output from a computer is of a type other than those marked with an asterisk among the memory numbers 6 to 39, it is automatically output according to the specifications of the projector.

# Specifications

OPTICAL	
Projection system	3 LCD panels, 1 lens projection system
LCD panel	1.3-inch p-Si TFT LCD panel with Micro Lens Array 2,359,296 pixels (786,432 pixels x 3)
Projection lens	Approx. 1.3 times zoom lens, F1.7 to 2.0, f50.8 to 64.0 mm
Lamp	300 W UHP lamp
Screen coverage	40 to 300 inches (viewable area, measured diagonally)
Light output	5200 ANSI lumens
SIGNALS	
Color system	NTSC, PAL, SECAM, NTSC <sub>4.43</sub> , PAL-M, PAL-N (automatically/manually selected)
Resolution	VIDEO: 750 TV lines, RGB: 1024 x 768 pixels
Acceptable signals	RGB (fH: 19 to 92 kHz, fV: 48 to 92 Hz (up to UXGA 60Hz)), 15 kHz component 50/60 Hz system, Progressive component 50/60 Hz system, DTV (480/60i, 575/50i, 480/60p, 575/50p, 720/60p, 720/50p, 1080/60i, 1080/50i), Composite video, S video
GENERAL	
Cabinet color	White
Power requirements	AC 100 to 240 V, 50/60 Hz
Power consumption	Max. 400 W, Standby 5 W
Operation temperature	0 to 35 °C (32 to 95 °F)
Operating humidity	35 to 85 %
Dimensions	480 (W) x 167 (H) x 502 (D) mm (19 x 6 5/8 x 19 7/8 inches)
Mass	Approx. 10.5 kg (23 lb 2 oz)
Heat dissipation	1365 BTU
INPUTS/OUTPUTS	
VIDEO IN	Loop-through BNC type
VIDEO	1.0 Vp-p ±2 dB, sync negative, 75 Ω
S VIDEO	Loop-through Mini DIN 4-pin (female)
Y	1.0 Vp-p ±2 dB, sync negative, 75 Ω
C	Burst 0.286 Vp-p ±2 dB (NTSC), 75 Ω or 0.3 Vp-p ±2 dB (PAL), 75 Ω
INPUT A	
Analog RGB/Component	5 BNC (female)
R/R-Y	0.7 Vp-p ±2 dB, positive, 75 Ω
G	0.7 Vp-p ±2 dB, positive, 75 Ω
G with Sync/Y	1.0 Vp-p ±2 dB, sync negative, 75 Ω
B/B-Y	0.7 Vp-p ±2 dB, positive, 75 Ω
SYNC/HD	
Composite sync	1.0 to 5.0 Vp-p, high impedance positive/negative
Horizontal sync	1.0 to 5.0 Vp-p, high impedance positive/negative
VD	
Vertical sync	1.0 to 5.0 Vp-p, high impedance positive/negative
INPUT B	
Digital/Analog RGB	DVI-I (TMDS)
INPUT C	
ETHER	10BASE-T/100BASE-TX
PC Card slot	PC Card slot Type II

MONITOR OUT*1	HD D-sub 15-pin (female) R/R-Y, G/Y, B/B-Y: Gain Unity, 75 Ω SYNC/HD, VD: 4.0 Vp-p (open), 1.0 Vp-p (75 Ω)
RS-232C	D-sub 9-pin (female)
CONTROL S IN / PLUG IN POWER	Stereo mini jack 5.0 Vp-p Plug in power DC 5 V maximum output 60 mA
TRIG	Mini jack POWER ON: 12 V output impedance 4.7 kΩ POWER OFF: 0 V

## SAFETY REGULATIONS

UL, cUL, DHHS, DNHV, FCC Class A, IC Class A, NEMKO,  
CE (LVD, EMC), C-Tick, CCC, VCCI Class B, JEIDA

## ACCESSORIES

Supplied accessories	Remote Commander*2 AA size Battery (2) Lens Cap Operation Manual Operation Manual for Networking Recommended PC Card/Wireless LAN Access Point List Installation Manual for Dealers
Optional accessories	Projector Lamp (for replacement) LMP-F300 Fixed Short Focus Lens VPLL-FM21 1.1 times zoom Short Focus Lens VPLL-ZM31 1.5 times zoom Long Focus Lens VPLL-ZM101 Suspension Support PSS-620 Signal Cable SMF-400/410

## DIMENSIONS

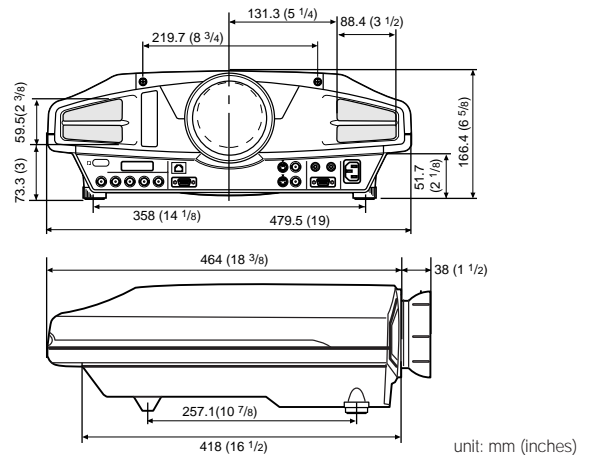

\*1 Digital RGB and Component signals are not output from the MONITOR OUT terminal.

\*2 Laser Type: Class II  
Wavelength: 645 nm  
Output: 1 mW



©2002 Sony Corporation. All rights reserved.

Reproduction in whole or in part without permission is prohibited.

Features and specifications are subject to change without notice.

All non-metric weights and measures are approximate.

Sony is a registered trademark of Sony Corporation.

Microsoft, Windows and PowerPoint are registered trademarks of Microsoft Corporation.

Macintosh is a registered trademark of Apple Computer, Inc.

**Distributed by**



**Power consumption during standby 5.0 W.**

**Lead-free solder is used for soldering in main portions.**

**Halogenated flame retardant is not used in cabinets.**