

17" modero® widescreen touch panel



AT FIRST SIGHT

If seeing is believing, then you will enjoy the expanded view of our 17" Modero Widescreen Touch Panel, the industry's first widescreen panel available exclusively from AMX. No other panel on the market compares in size and power. Take control with Table Top or Wall/Flush Mount models to see for yourself.

WIDER IS BETTER

Control and automate many different devices all at once. Handle multiple applications on a split-screen. Manage a videoconference with full-screen picture and control features. Watch a video while monitoring security. Experience greater control possibilities through a significantly wider AMX Touch Panel.

ANYWHERE, ANY TIME CONTROL

Experience the freedom to take control from any location with the same Modero Wireless Solution accessories, including the Modero Battery Base Kit, Battery Station and Power Packs, and Wireless Interface Card.



17" modero® widescreen touch panel

NXT-CV17 & NXD-CV17 WIDESCREEN VIDEO TOUCH PANELS

LCD

- 17" TFT active-matrix LCD (1280 x 768 pixel resolution)
- Viewing Angle: Ultra-wide +85° viewing in all directions
- Dot pixel pitch: 0.289 mm
- Display colors: 16 million (24-bit color depth)
- Active View Area: 14.55" x 8.73" (36.96 cm x 22.18 cm)

POWER

- 3.87 Amps @ 12.0 VDC

MEMORY

- 256MB Extended Memory Module (standard)
- 128MB Compact Flash factory programmed with panel firmware (upgradable to 1 GB)

DIMENSIONS (HWD)

NXT-CV17:

- 13.29" x 17.84" x 12.44" (33.76 cm x 45.31 cm x 31.6 cm)
- Fully lowered height: 6.23" (15.82 cm)

NXD-CV17:

- Faceplate included: 14.44" x 18.09" x 3.31" (36.68 cm x 45.95 cm x 8.41 cm)
- CB-CV17 Conduit/wallbox: 13.55" x 17.07" x 3.49" (34.424 cm x 43.38 cm x 8.85 cm)

ENCLOSURES

NXT-CV17:

- ABS Polycarbonate enclosure in black matte finish with platinum color bezel trim

NXD-CV17:

- Metal enclosure with ABS Polycarbonate front bezel in black matte finish with platinum color trim

FRONT PANEL

- Light Sensor: Photosensitive light detector for automatic adjustment of the panel brightness
- Motion Sensor (PIR): Proximity Infrared Detector to wake the panel when the panel is approached
- Front Setup Access Button: Pushbutton (grey) used to either put the panel into a "sleep" or "wake" state and/or access the Setup and

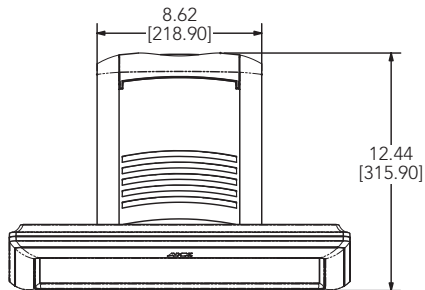

NXT-CV17 (Top)

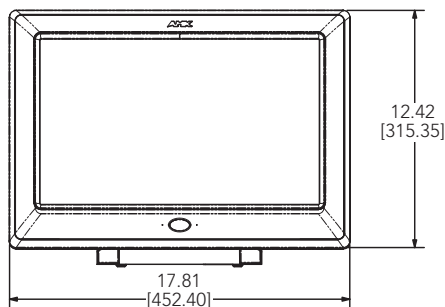

NXT-CV17 (Front)

NXD-CV17 (Side)

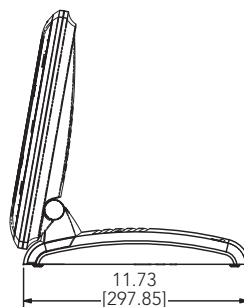

NXD-CV17 (Right side showing connectors)

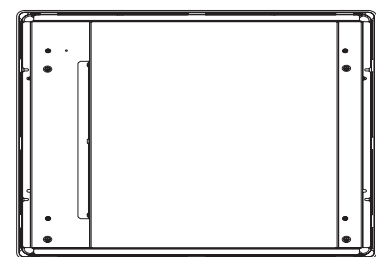
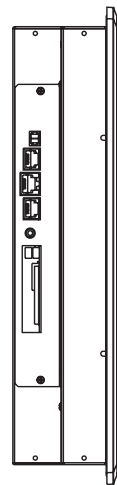

NXD-CV17 (Rear)

- Calibration pages
- Speakers: Frequency response 450 Hz - 7 KHz
- Microphone: Used for audio/video conferencing applications

CONNECTORS

- NXT-CV17 located on back & NXD-CV17 located on the side
- PCMCIA Card Slot: Provides optional wireless connectivity (with optional upgrade)
- Headphone Connector: Stereo output through a 3.5mm mini-jack (for use with external speakers)
- Audio/Video Connector: RJ-45 connector cable for Audio/Video signals from the NXA-AVB Breakout Box
- Ethernet 10/100 Port: RJ-45 port for 10/100 Mbps communication with LEDs that show Link and Activity
- ICSNet Connector: RJ-45 connection for ICSNet interface
- 2-pin Power Connector (Male)

AV FEATURES

- Displays NTSC/PAL/SECAM video in variable-size video window
- Sound option (including speakers and audio/headphone connections)
- NXA-AVB Breakout Box included with NXT-CV17 and NXD-CV17
 - Provides video/audio distribution over CAT5 cable (200 feet)
 - Accepts either Composite or S-Video with Adapter

OPTIONAL ACCESSORIES

- PSN6.5 Power Supply (13.5 VDC)
- CB-TP17 Conduit Wall box (optional for all NXD touch panels)
- NXA-RK17 Rackmount kit for 17" Wall Mount Touch Panels
- Upgrade Compact Flash (factory programmed with firmware):
 - NXA-CFTP256M - 256 MB compact flash card
 - NXA-CFTP512M - 512 MB compact flash card
 - NXA-CFTP1G - 1 GB compact flash card
- NXA-BASE/B: Wireless base for Table Top Touch Panel (NXT only)
- NXA-WC80211b: 802.11b wireless interface card
- NXT-BP: Battery pack for Table Top Touch Panel. Provides 3 hours of continual operation (NXT versions only)
- NXT-CHG: Battery charger for NXT-BP batteries. (NXT versions only)

WEIGHT

- NXT-CV17: 17.25 lbs (7.82 kg)
- NXD-CV17: 15.5 lbs (7.03 kg)



IT'S YOUR WORLD. TAKE CONTROL.

ARGENTINA • AUSTRALIA • BELGIUM • BRAZIL • CANADA • CHINA • ENGLAND • FRANCE • GERMANY • GREECE • HONG KONG • INDIA • INDONESIA • ITALY • JAPAN
 LEBANON • MALAYSIA • MEXICO • NETHERLANDS • NEW ZEALAND • PHILIPPINES • PORTUGAL • RUSSIA • SINGAPORE • SPAIN • SWITZERLAND • THAILAND • TURKEY • USA
 ATLANTA • BOSTON • CHICAGO • CLEVELAND • DALLAS • DENVER • INDIANAPOLIS • LOS ANGELES • MINNEAPOLIS • PHILADELPHIA • PHOENIX • PORTLAND • SPOKANE • TAMPA
 3000 RESEARCH DRIVE, RICHARDSON, TX 75082 • 800.222.0193 • 469.624.8000 • +1.469.624.7400 • 469.624.7153 fax • www.amx.com